

**GUIDELINES FOR THE ASSESSMENT OF  
DRAWDOWN ESTIMATES  
FOR WATER RIGHT APPLICATION PROCESSING**

**by**

**Tom Morrison, P.E.  
Chief, Hydrology Bureau**

**NEW MEXICO OFFICE OF THE STATE ENGINEER  
HYDROLOGY BUREAU REPORT 06 – 01**

**February 1, 2006**

## **Acknowledgements**

I wish to express my appreciation to all members in the Hydrology Bureau for their careful and thoughtful assistance. Susan Hoines, Mike Johnson, and Jack Frost deserve special mention and thanks for their invaluable advice and support throughout the development of the project. Margaret Porter's work in developing the figures into their present form is greatly appreciated. I would also like to acknowledge Doug Rappuhn, Peggy Barroll, and Alan Cuddy for their insightful suggestions and careful reviews.

## **Introduction**

To process an application to appropriate groundwater an evaluation is made to assess drawdown on existing nearby wells. Well diversions will generally cause some degree of water level decline in nearby wells but this drop may not necessarily create a hardship to well production. A lowering of the water level may result in uneconomical well operation (economic hardship) or may influence the ability of nearby wells to produce the quantity of water required (physical hardship).

The purpose of this report is to provide guidelines for the assessment of degree of hardship that will result from drawdown caused by a proposed groundwater diversion.<sup>1</sup> Other types of investigations, such as water supply longevity studies, may also find the methods useful to apply. Flexibility in applying the guidelines is necessary due to unique well characteristics and hydrologic conditions, in addition to varying degrees of data availability.

## **Overview of Evaluation Guidelines**

The guidelines provide a general approach to assess drawdown estimates on wells in the vicinity of a proposed well, but geologic, well completion, and well response conditions influence how the guidelines should be applied. Data availability and reliability are important factors influencing evaluation procedures along with the degree of drawdown in a given area. Only a few steps may be necessary to reach a conclusion where water level declines are small but a greater number of steps may be necessary in areas involving large water level declines or cases involving protestants.

An assessment of hardship to existing wells begins by evaluating well logs to select the allowable water level decline existing wells may tolerate. As water levels decline, the pumping water level may descend to a level where well operations become uneconomical. This level can estimated based on the assumption that a well may become uneconomical once the water column has been reduced to 70 percent of the current water column. In addition, it is possible to estimate the pumping water level at which the required well yield cannot be physically sustained. This second level is determined based on the well construction, aquifer conditions, and pump characteristics (Figure 1).

Once the allowable drawdowns for an existing well have been determined, the next step is to apply model results to obtain the total drawdown on the well. The total drawdown results from impacts by 1) the proposed pumping, 2) diversions by existing wells, and 3) self-induced influences of the nearby well as pumps are cycled on and off (Figure 2). By comparing the total drawdown to allowable drawdowns, an assessment of the degree of impact is made.

---

<sup>1</sup> Where available, basin guidelines should also be applied to process well applications.

## **Estimations**

### Water Column (WC)

For wells other than domestics completed in basin fill aquifers, the water column is often selected as the difference between the current non-pumping water level and depth to the base of the well screen within the primary production zone (Figure 3). Due to the low volume of water produced by domestic wells, and other construction factors, the total well depth is often assumed as the base of the water column. In the absence of current water level data, historical water levels, corrected for water level declines up to the present, may be applied.<sup>2</sup>

### Drawdown due to Existing Water Rights (DE)

Regional groundwater models have been adopted by the agency for a number of basins to estimate future impacts due to the use of existing rights. If the agency has not adopted a model for the area of interest, it may be necessary to develop one, or work with an existing non-agency model. For areas with sparse development, or where model development is unjustified due to data limitations, historical water level declines may be projected to obtain drawdown estimates. Calculations are typically performed 40 years into the future from the time of hydrologic review.

### Drawdown due to Proposed Use (DP)

The Theis equation is typically used to calculate 40-year drawdowns due to the use of a proposed well. Drawdowns calculated by a numerical model may be used, but may not be representative of the actual cone of depression near a pumping well. This is typically the case if nearby wells are located in the same model cell with the proposed well or if the numerical model over-simplifies well spacing.

### Dynamic Drawdown (DD)

The dynamic drawdown represents the self-induced decline inside the casing of the existing well as pumps are cycled on and off. If well test information is available, the specific capacity (SC) may be applied to obtain the dynamic drawdown by dividing the anticipated production rate (Q) for a pumping cycle by SC ( $DD = Q/SC$ ). If transmissivity (T) is available it may be used to estimate SC under certain conditions (see page 61, Heath, 1983; or Appendix 16.D, Driscoll, 1986). For some domestic wells, a ten-foot DD may be reasonable unless information supports another value. The procedures below should be used for wells other than domestics if SC is unknown.

Drawdowns obtained from the Theis equation at the radius of the well reflect drawdowns in the aquifer near the edge of the borehole (unadjusted dynamic drawdowns). Due to well inefficiency, an additional step is necessary to obtain the actual pumping water level inside the casing (Figure 4).

---

<sup>2</sup> Maintaining a 40-year water supply for nearby wells from the date of evaluation is a criterion for the initial pass at examining local well impacts. If wells are not capable of achieving this life expectancy, due to well age in part, additional considerations are necessary. These considerations are discussed in the Application of Results section.

To compute the unadjusted dynamic drawdown a pumping rate must be selected that is representative of actual operational practices. Since wells are not operated 100 percent of the time, allowances are required to obtain the rates corresponding to the fraction of time wells are actually pumped. A 60 percent production time over one day is typically assumed for public supply, industrial, and commercial use wells. Due to the variable nature of pumping schedules for irrigation wells, typically the drawdown at the end of the irrigation season is calculated assuming full time production during this period. Alternatively, if pumping schedules can be reasonably approximated the operational well yield may be estimated.

Once drawdown is estimated it is adjusted using the well efficiency. Typically a well efficiency of 70 percent is assumed. A higher efficiency such as 80 percent may be appropriate for uncased wells and 60 percent is probably more realistic for less than ideal conditions (page 59, Heath, 1983). The drawdown inside the casing (DD) is obtained by dividing the unadjusted dynamic drawdown by the well efficiency.

#### Total Drawdown (DT)

The estimated water level declines due to existing water rights (DE), the proposed use (DP), and self-induced dynamic drawdown (DD) are summed to obtain DT.

#### Allowable Economical Drawdown (AED)

Allowable economical drawdown is calculated based on the percent of water column that can be lost before the well loses economic viability. In the absence of more reliable data, a value of 70 percent of the water column may be assumed as the allowable economic drawdown (Figure 5).<sup>3</sup>

#### Allowable Physical Drawdown (APD)

Physical hardship is the loss of the required well yield due to excessive water level decline. It is assessed by comparing the allowable physical drawdown, which is the difference between the static water level and the lowest practical pumping water level, to the total predicted drawdown. The lowest practical pumping water level (LPPL) depends on the flow rate required, depth at which the pump is set, pump characteristics, and other factors. The LPPL is often assumed because pump settings and characteristics are usually not available.

For some non-domestic wells, where water levels are well above the screen, the LPPL may be assumed at 20 to 30 feet above the top of the well screen unless there is information to the contrary. Due to the low volume of water produced by domestic wells, and other construction factors, some wells may be constructed with pumps set within the screen interval or close to the bottom of the well. The LPPL is typically assumed to be 20 feet above the bottom of the well for domestic wells unless a different value is supported.

---

<sup>3</sup> Driscoll (1986) indicates (p. 217) that a water table aquifer well becomes uneconomical to operate if drawdown exceeds 67 percent of the water column. The majority of the well yield (90 percent) is obtained at 67 percent of maximum drawdown and the extra pumping costs would be out of proportion to the increase in yield. For administrative purposes, a value of 70 percent is suggested. The procedures may also be considered on a case-by-case basis for wells tapping a confined aquifer.

At least 20 feet may be necessary to maintain submerged conditions and to allow a pump setting above the bottom to avoid sediment problems (Figure 6).

## **Procedures**

The list below provides a general description of the steps that may be required (several example problems are attached following Figure 6). Other steps beyond the scope of this report will also be necessary such as the modeling approach and number of wells to be included in the evaluation.

1. Estimate the existing water column (WC).
2. Multiply WC by 0.70 to obtain allowable economic drawdown (AED).
3. Estimate drawdowns due to existing water rights (DE).
4. Estimate drawdowns due to proposed use (DP).
5. Estimate dynamic drawdown (DD).<sup>4</sup>
6. Add results from steps 3 through 5 to obtain the total drawdown (DT).
7. Estimate lowest practical pumping level (LPPL) in relation to base of water column or total well depth, as appropriate.
8. Subtract LPPL from water column to obtain the allowable physical drawdown (APD).
9. Tabulate results.
10. If drawdowns exceed the allowable economic or physical drawdown, proceed to the next section.

## **Administrative Drawdown Allowances**

The guidelines above are useful for identifying cases where a recommendation is clearly evident. If this is the case the technical evaluation may be concluded. However, for borderline situations where the most severe impacts are slightly greater than allowable declines, decision makers may decide that stringent enforcement of the limits is unreasonable given the level of uncertainty involved. An approach similar to the one used in basin specific guidelines may be considered to obtain the limit of allowable impacts.

Several basins are administered with guidelines allowing for small marginal affects on Critical Management Areas (CMAs). These areas have predicted water level declines that are excessive in relation to the aquifer thickness and average well completion conditions within each basin. The approach used to select administrative drawdown allowances for the CMAs may also be applied to wells.<sup>5</sup>

For basins with thick alluvial aquifers, such as Middle Rio Grande Basin (MRGB), a drawdown allowance of 10.0 feet over a 40-year period has been selected for the CMA. This administrative drawdown allowance may be selected for wells within the MRGB or for wells in other basins with similar hydrologic conditions. A value of 4.0 feet over a 40-year period was selected for the Estancia and Tularosa CMAs. For basins with thin

---

<sup>4</sup> The estimation of dynamic drawdown may only be necessary in cases where the estimated decline from existing and proposed uses is near the allowable drawdown.

<sup>5</sup> Wells with declines exceeding the allowable economic or physical drawdown are defined as "Critical Wells". CMAs are areas in which Critical Wells are common.

alluvial aquifers, such as in southeastern New Mexico, an allowable 40-year drawdown of 2.0 feet upon a CMA is being considered. These allowances may be considered in the selection of drawdown allowances for other basins.

### **Application of Results by Decision-Makers**

Although the use of a proposed well may cause declines that exceed the economic, physical, or administrative drawdown allowances, water right decision-makers may wish weigh other circumstances before rendering a decision. Several factors may influence decision-making.

- Validity of the water right of the affected well.
- Age of well relative to anticipated well life and ability to deepen to regain supply.
- Whether the well completion is reasonable in relation to average well completions in the area.
- Potential to approve the application for less than the requested diversion to maintain water level declines within allowable limits.
- Potential to condition approval upon the acceptance of a groundwater monitoring and remediation plan.
- Potential to condition approval upon a plausible pumping distribution that provides acceptable impacts.

### **Conclusion**

The guidelines are intended to encourage technical consistency among cases with similar conditions while encouraging evaluation flexibility to address unique conditions. Reported well construction and aquifer conditions, in addition to data availability, should guide the evaluation approach. Staff should continue to evaluate, refine and develop new guidelines, as conditions require. Agency work products should clearly describe the basis for these improvements. This report should be updated as appropriate.

### **References**

Driscoll, F.G., 1986, Groundwater and Wells, Johnson Division, St.Paul, MN.

Heath, R.C., 1983, Basic Ground-Water Hydrology, United States Geological Survey Water-Supply Paper 2220.

# Water Level Decline Tolerances Economic and Physical

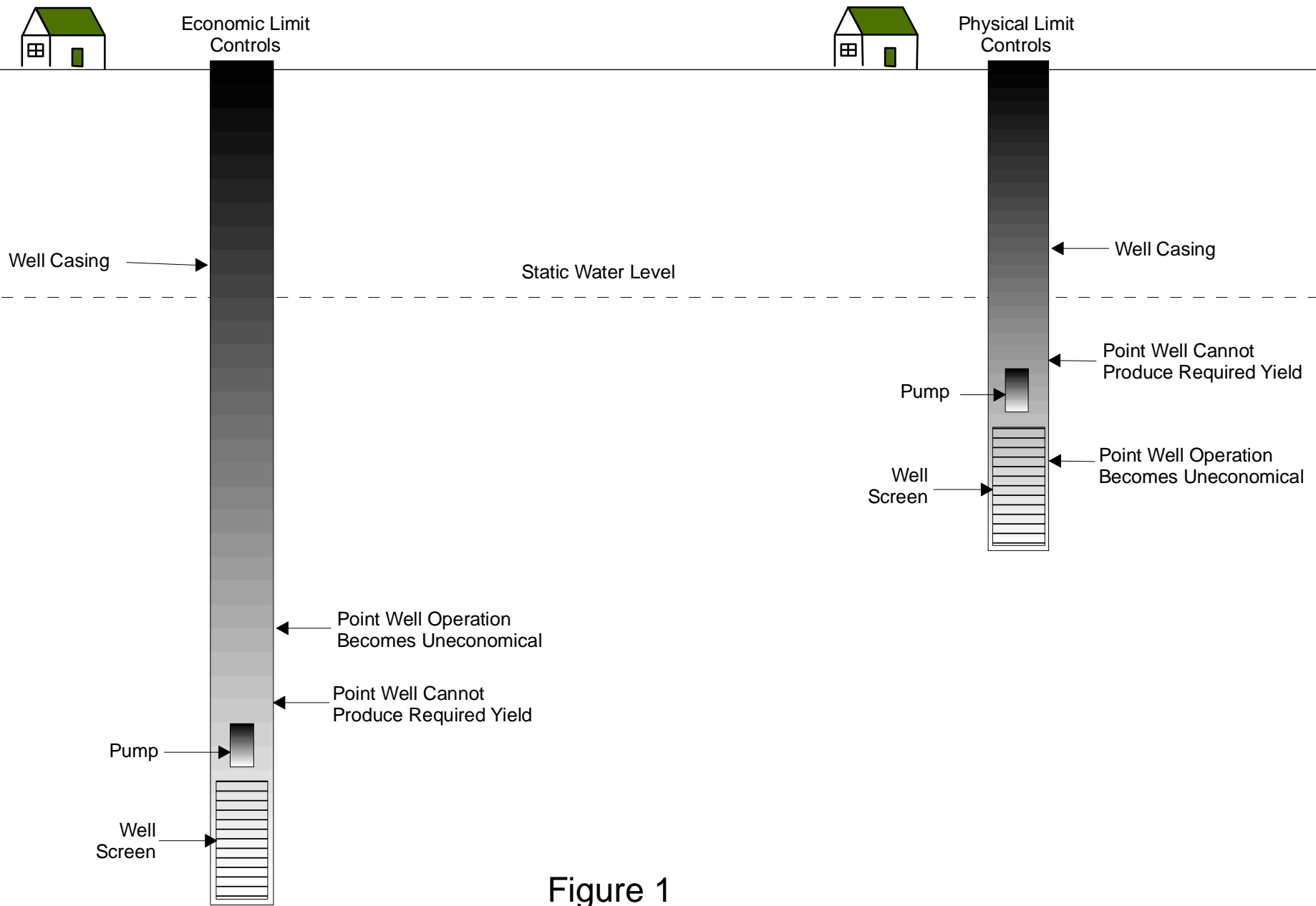

Figure 1

# Total Drawdown

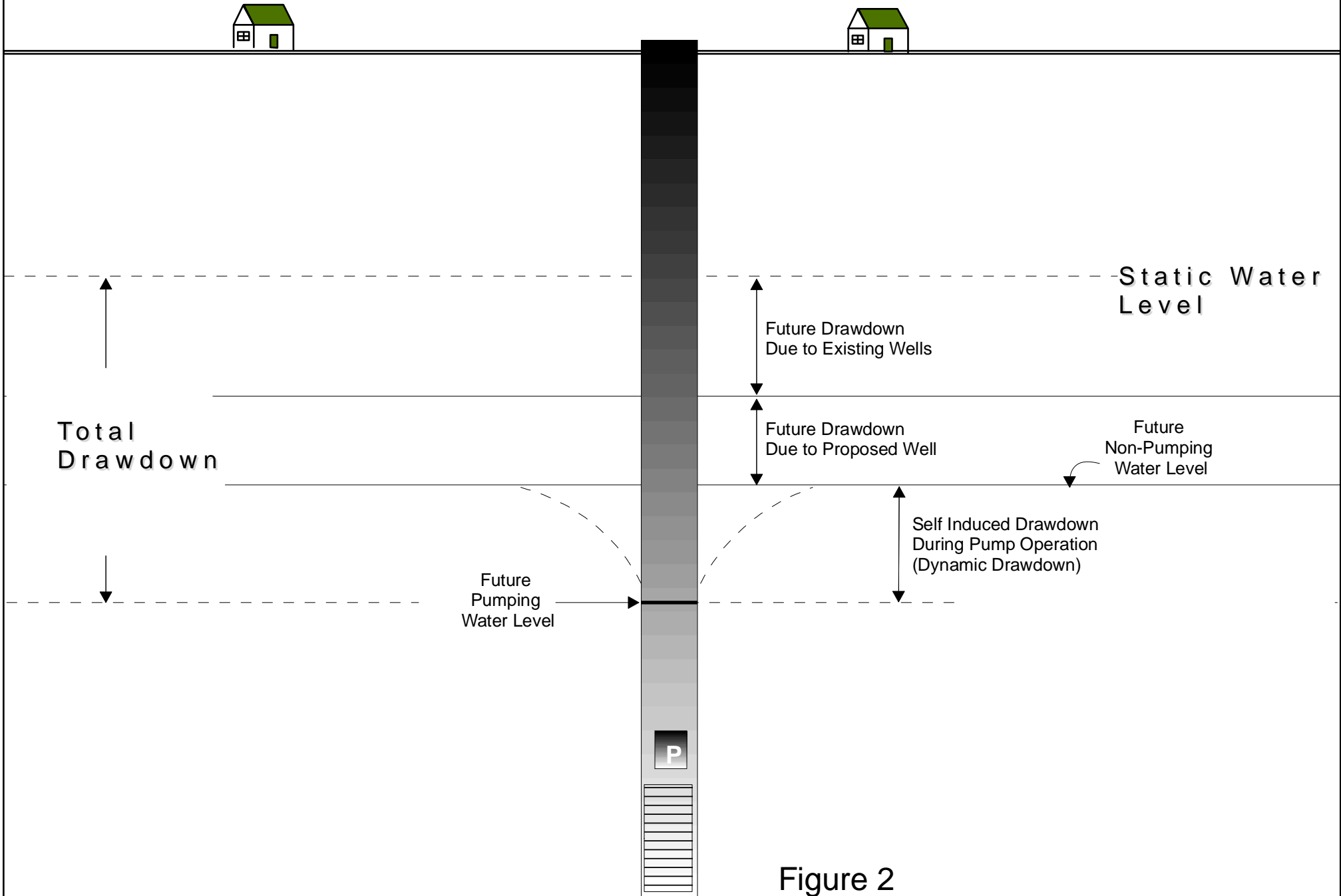
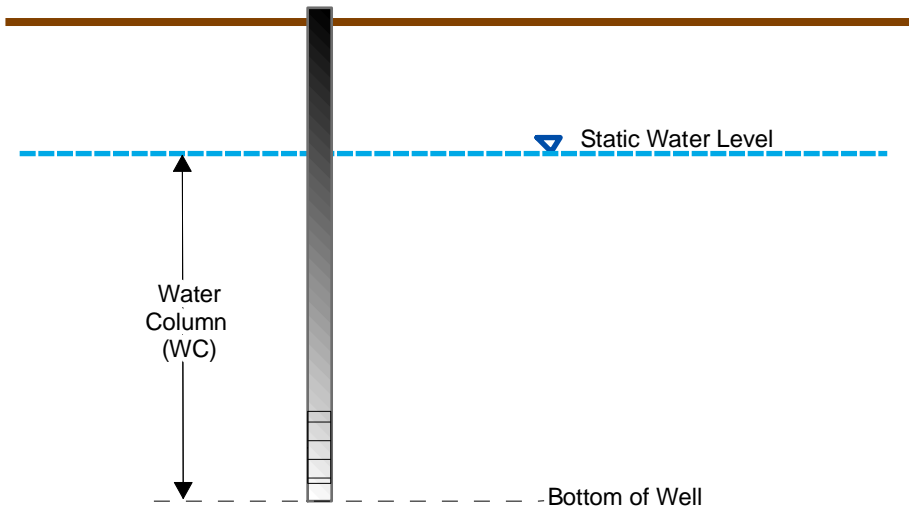

Figure 2

# Calculation of Water Column

Case 1: Case Where Water Column Limited by Well Depth



Case 2: Case Where Water Column Limited by Base of Aquifer

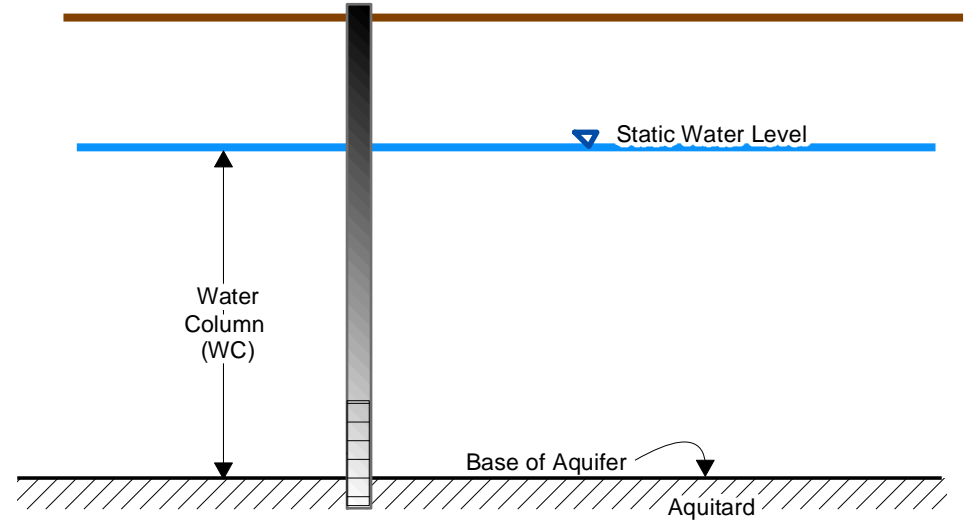

Case 3: Case Where Water Column Limited by Base of Screen Interval

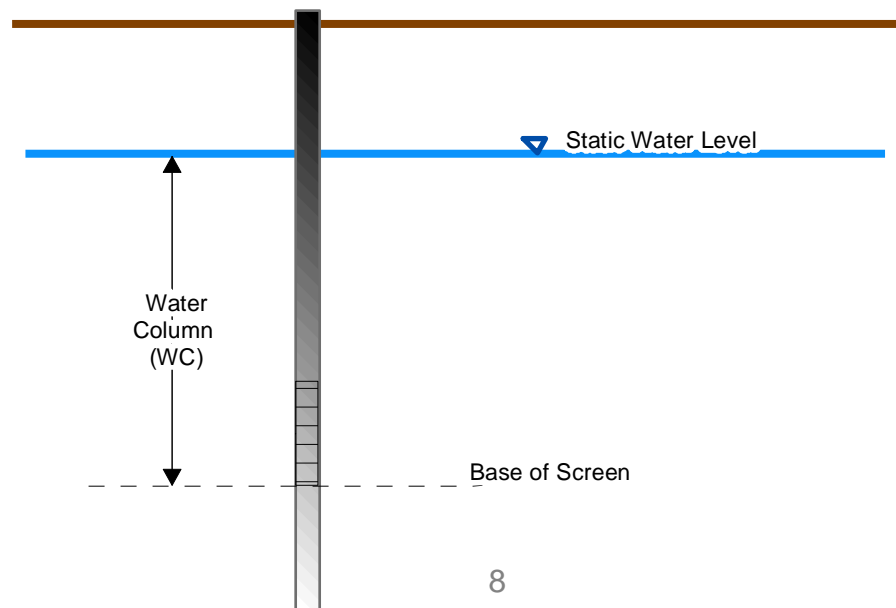

# Dynamic Drawdown

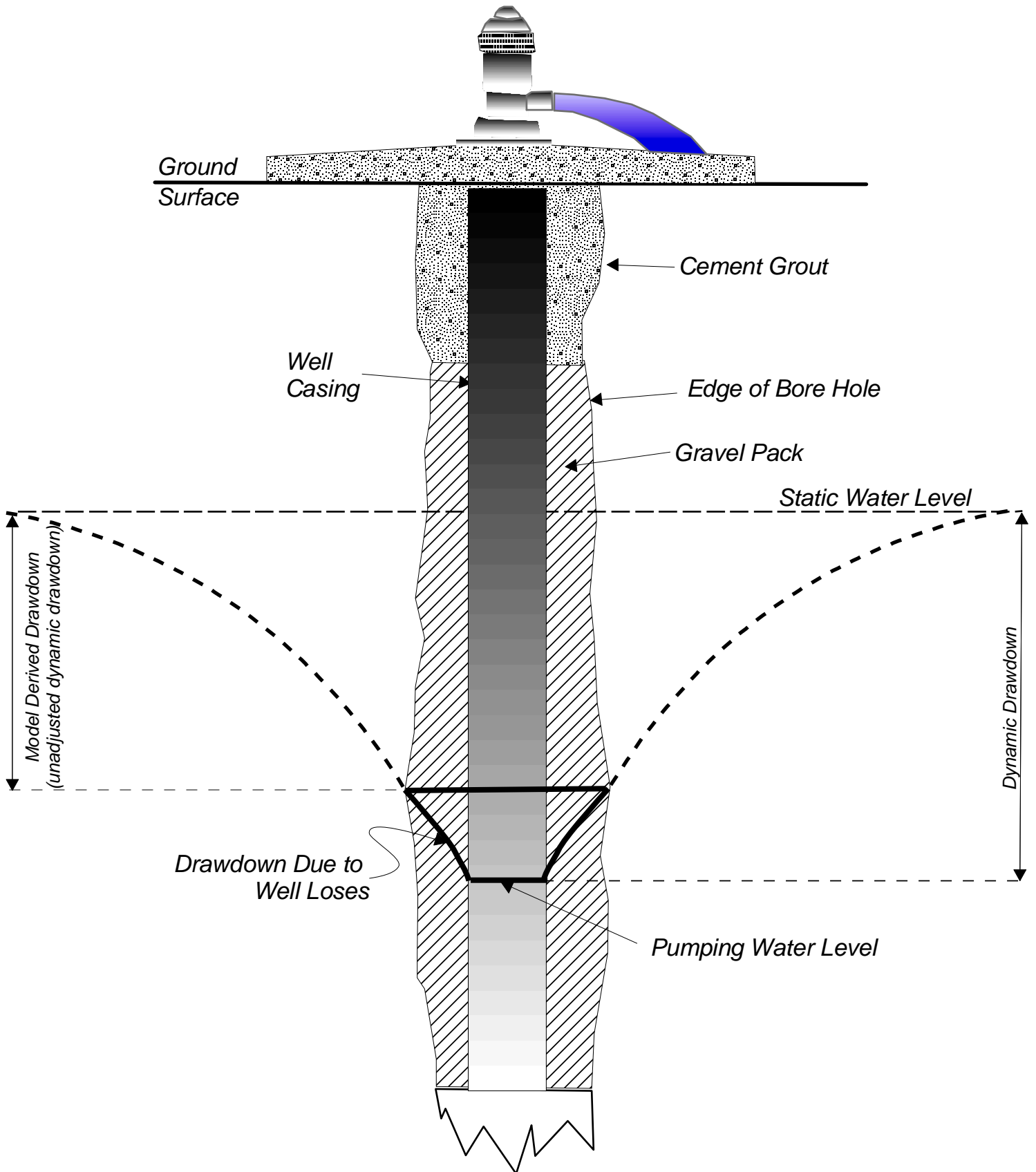

Figure 4

# Allowable Economic Drawdown

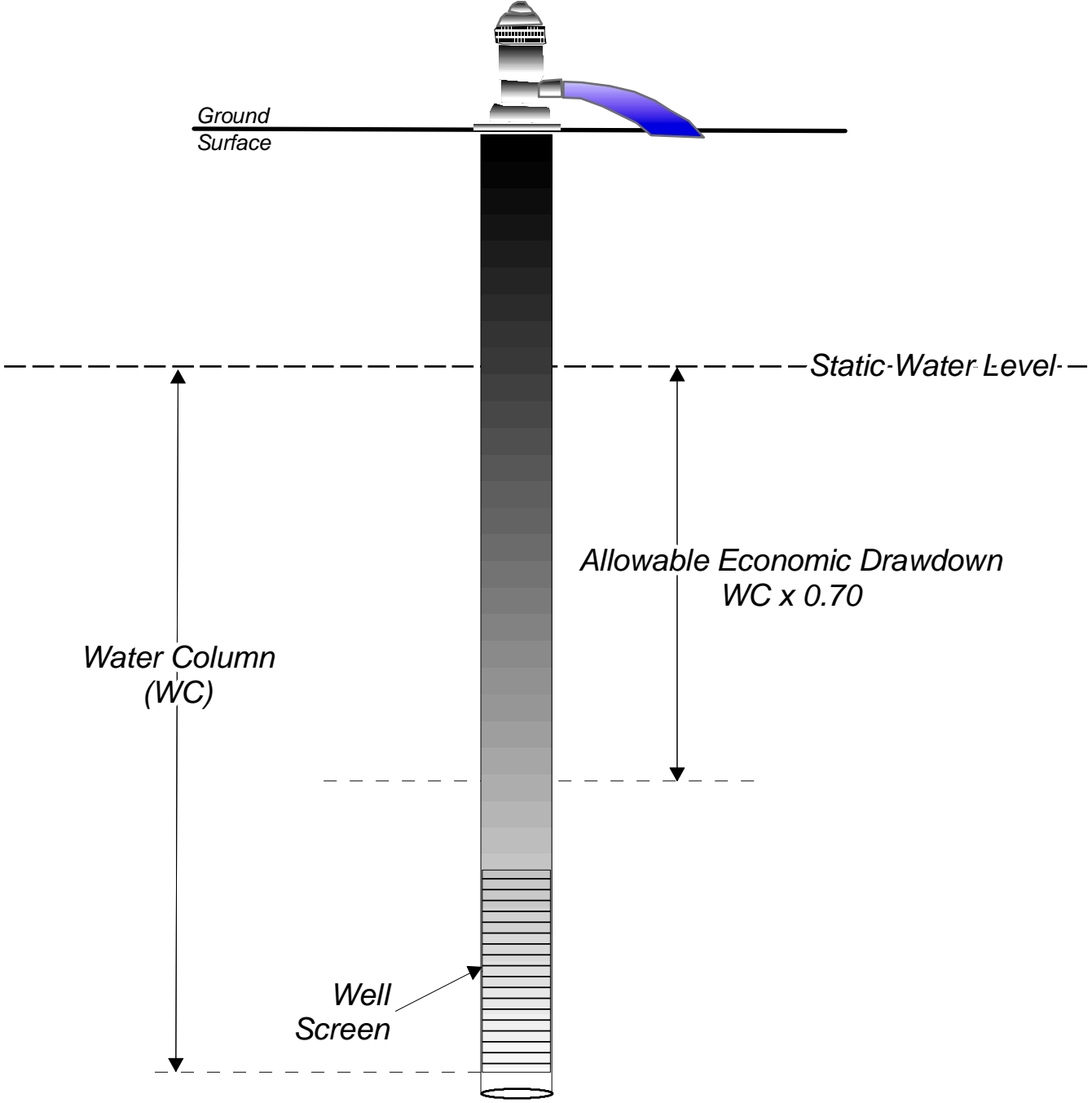

Figure 5

# Example of Allowable Physical Drawdown Domestic Well

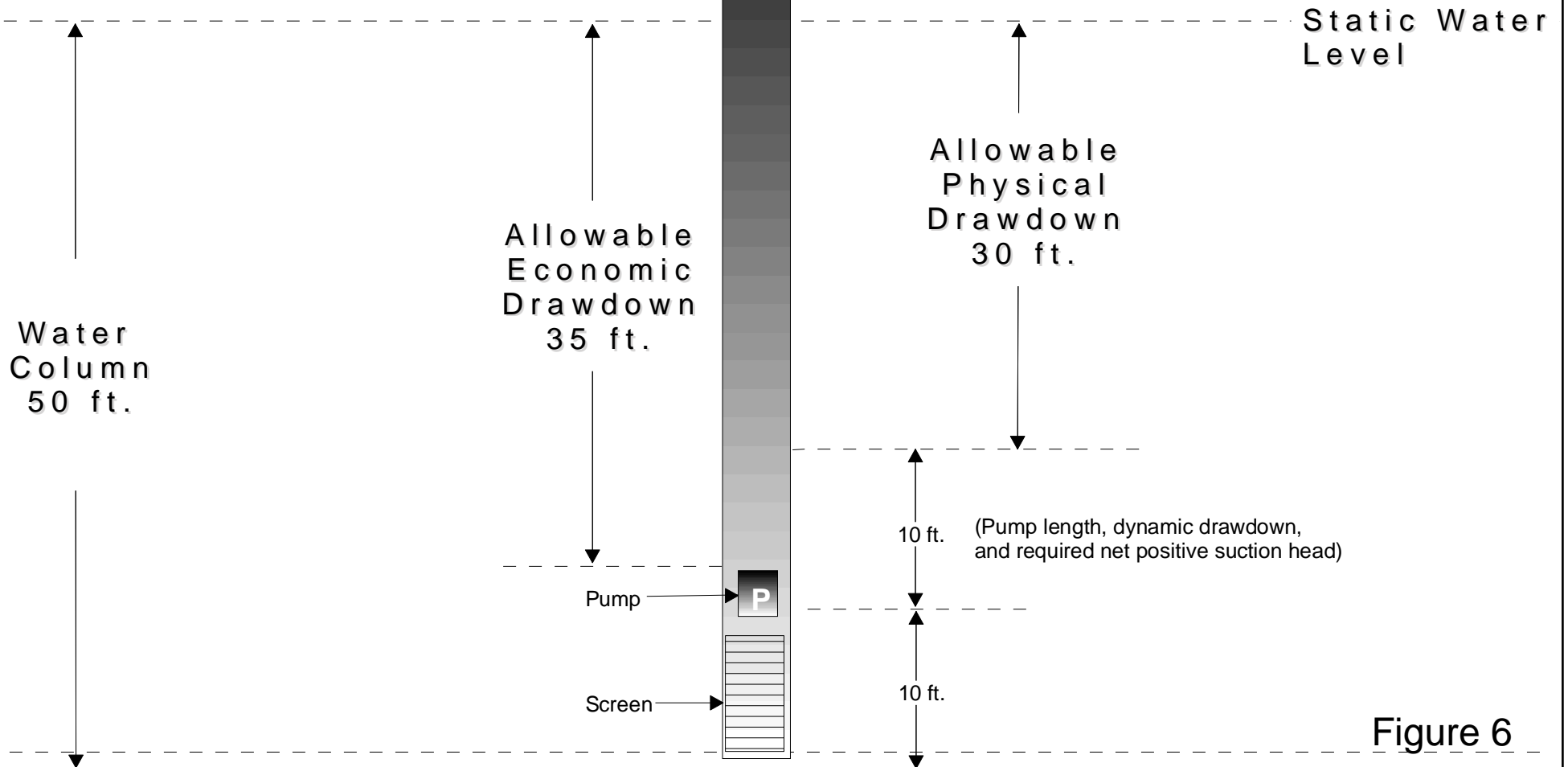

Figure 6

## Example Problems

Well #	Use	Depth to Base of Water Column bls (D)	Water Level 2006 (WL)	Water Column 2006 (WC) (WC= D - WL)	40-Year Drawdown From Existing Wells (DE)	40-Year Drawdown From Proposed Well (DP)	Dynamic Drawdown (DD)	Total Drawdown (TD= DE + DP + DD)	Allowable Drawdown Economic (AED)	Physical (APD)
Ex. 1	Dom.	150	50	100	40	10	10	60	70	80
Ex. 2	Irr.	400	60	340	40	20	40	100	238	230
Ex. 3	Irr.	170	50	120	80	50	10	140	84	100

**Conclusions:**

Wells in Example 1 and 2 remain viable

Well in Example 3 is unviable

## Example 1 Domestic Well Basin Fill Aquifer

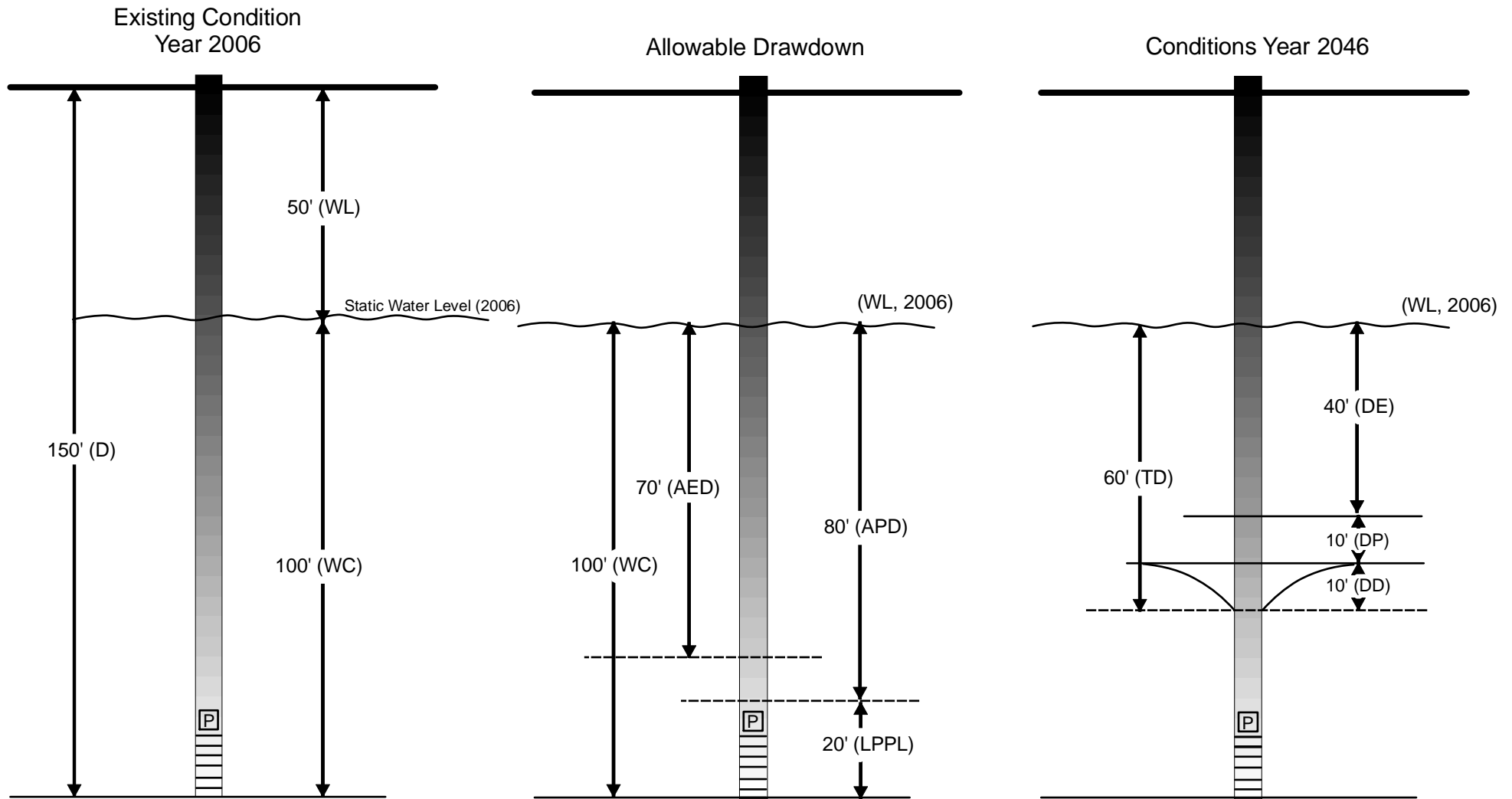

Key: WL- depth to the current water level; WC- length of water column; D- depth to production zone base; DE- drawdown existing water rights; DP- drawdown proposed well; DD- dynamic drawdown; TD- total predicted drawdown; AED- allowable economic drawdown; APD- allowable physical drawdown; LPPL- lowest practical pumping level above base of WC.

Notes:  
 $AED = WC \times 0.70 = 100' \times 0.70 = 70'$   
 APD: Assume lowest practical pumping level (LPPL) of 20' above base of WC for a domestic well.  
 $APD(Domestic) = WC - 20' = 100' - 20' = 80'$

## Example 2 Irrigation Well Basin Fill Aquifer

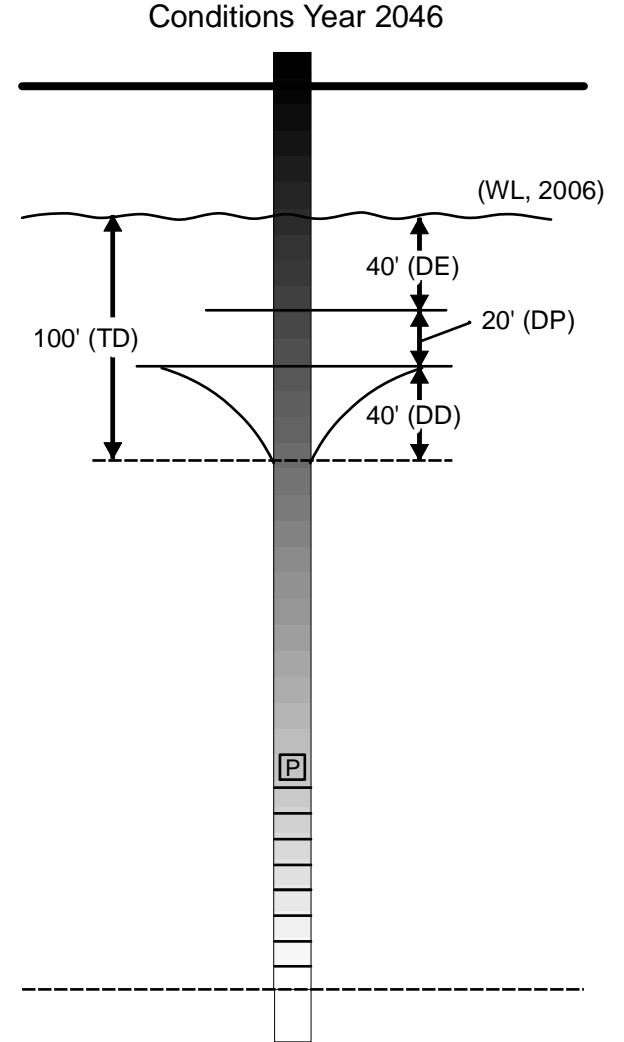
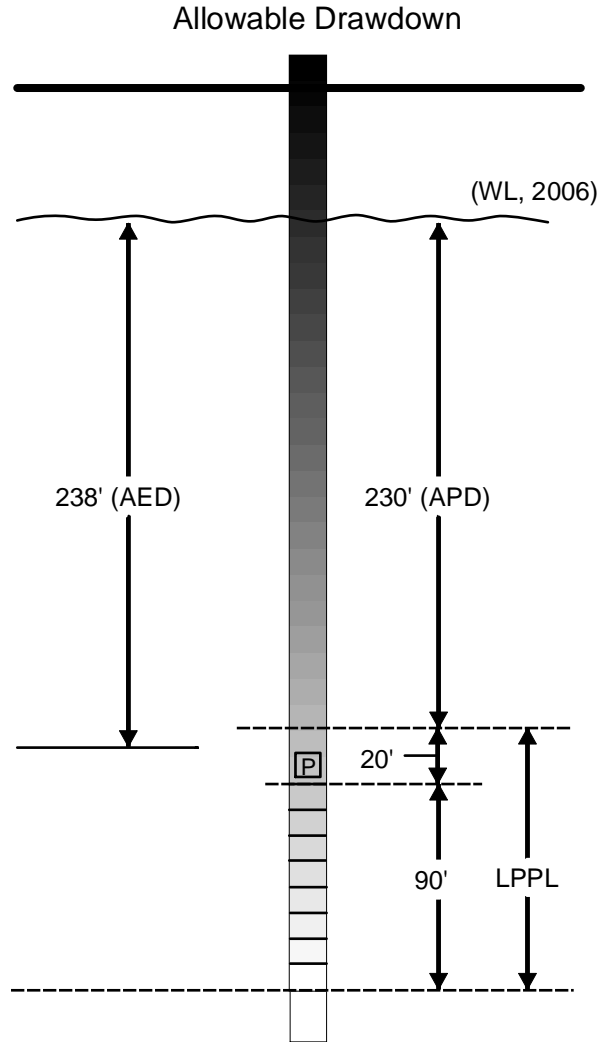
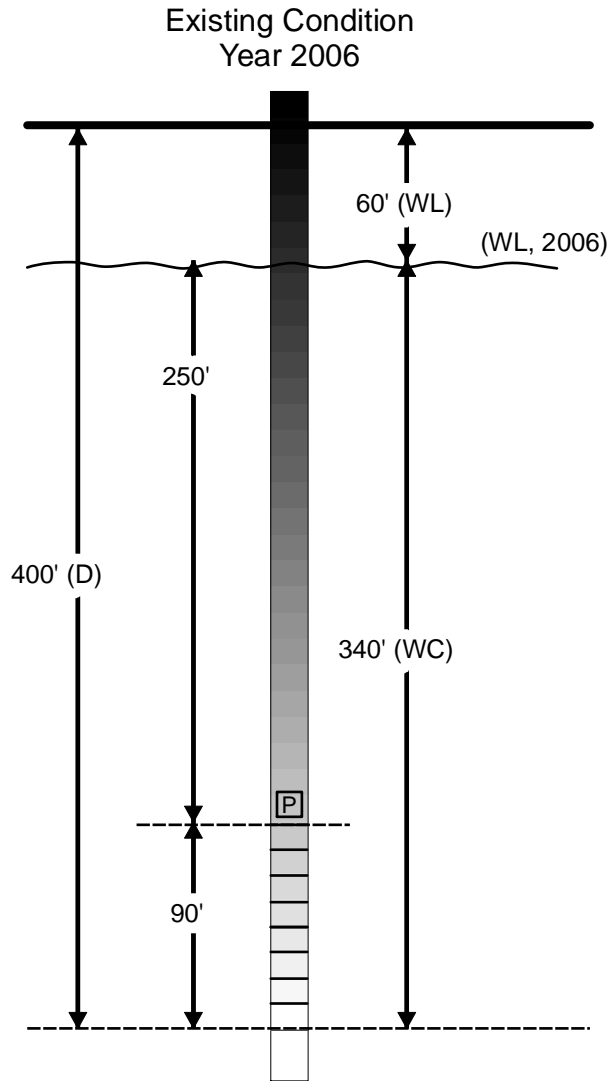

Key: WL- depth to the current water level; WC- length of water column; D- depth to production zone base; DE- drawdown existing water rights; DP- drawdown proposed well; DD- dynamic drawdown; TD- total predicted drawdown; AED- allowable economic drawdown; APD- allowable physical drawdown; LPPL- lowest practical pumping level above base of WC.

Notes:  
 $AED = WC \times 0.70 = 340 \times 0.70 = 238'$   
 $APD(\text{Irrigation Well}) = 20\text{ft. above well screen} = WC - \text{length of perforations} - 20' = 340' - 90' - 20' = 230'$

### Example 3 Domestic Well Limestone Aquifer

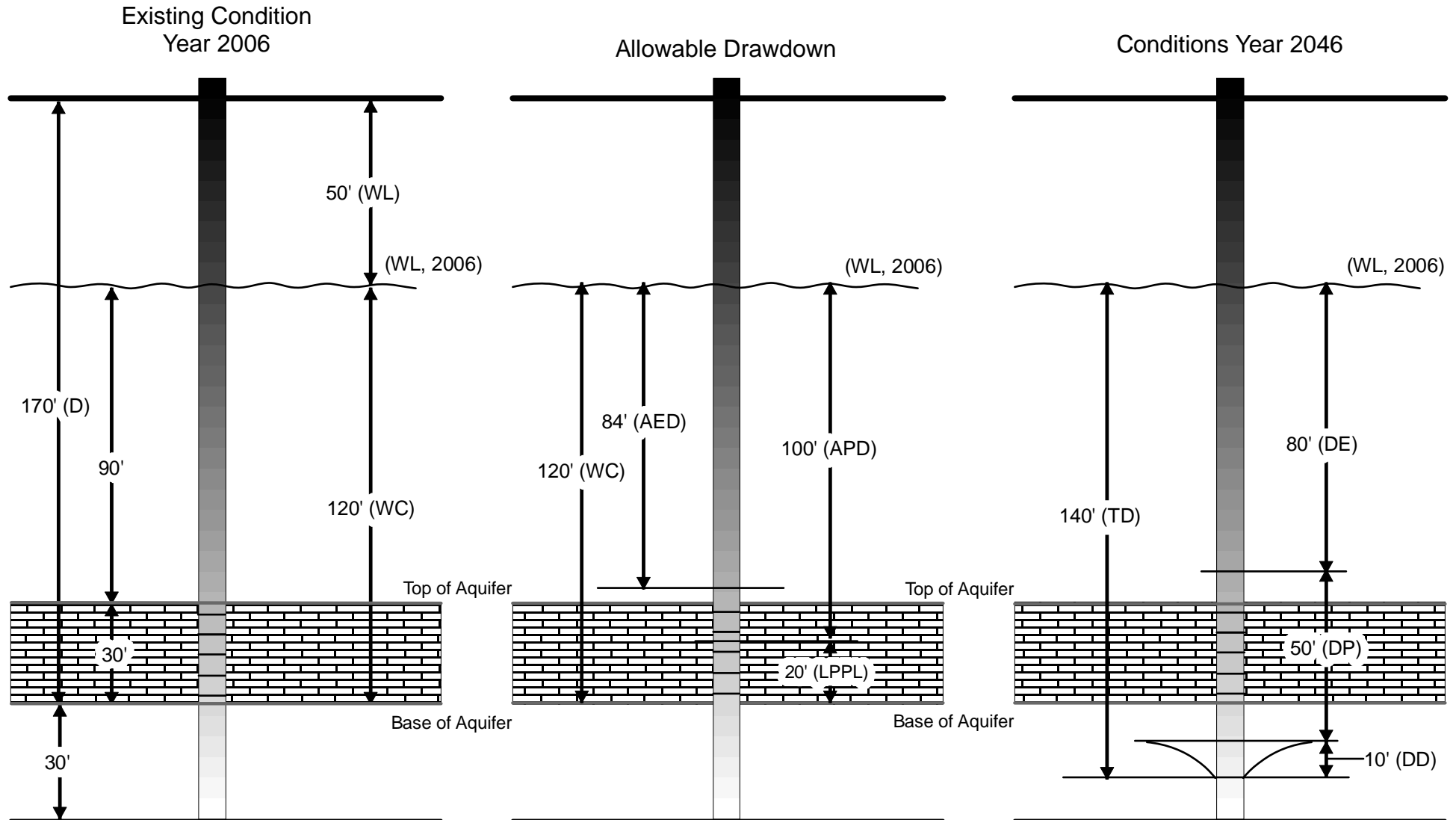

Key: WL- depth to the current water level; WC- length of water column; D- depth to production zone base; DE- drawdown existing water rights; DP- drawdown proposed well; DD- dynamic drawdown; TD- total predicted drawdown; AED- allowable economic drawdown; APD- allowable physical drawdown; LPPL- lowest practical pumping level above base of WC.

Notes:  
 $AED = WC \times 0.70 = 120' \times 0.70 = 84'$   
 $APD(\text{Domestic}) = WC - LPPL = 120' - 20' = 100'$