

Don't Waste A Drop



**WATER USE AND
CONSERVATION
BUREAU**
New Mexico Office of
the State Engineer

Finding, Fixing and Preventing Indoor Water Leaks





**WATER USE AND
CONSERVATION
BUREAU**

New Mexico Office of
the State Engineer
P.O. Box 25102
Santa Fe, NM
87504-5102
1-800-WATER-NM
www.ose.state.nm.us

Funded by a grant
from the U.S. Bureau
of Reclamation.
Produced for the
New Mexico Office of
the State Engineer
by Schultz
Communications,
Albuquerque, NM.
Designed & Illustrated
by Ken Wilson Design.

February 2002

This booklet is designed to provide basic information about some of the most common household water leaks and give you the practical information you need to make simple repairs and perform preventive maintenance that can prevent water waste. Finding and fixing water leaks will save water and reduce your water bills. However, the information presented here is not intended to fix major plumbing problems or substitute for the services of a professional plumber.

Cover photo courtesy of Delta Faucets

Preventing Water Waste is Everyone's Job

How Much Water Is Leaking?

Even a tiny leak can waste thousands of gallons of fresh water every month. Here's how much water is wasted by different kinds of leaks:

Pipe Leaks

(at 60 pounds of water pressure)

<u>Size of Hole</u>	<u>Gallons Wasted per Month</u>
1/32"	6,300
1/16"	25,000
1/8"	100,000
3/16"	225,000
1/4"	400,000

Faucet Leaks

60 drops per minute =
192 gallons wasted per month

90 drops per minute =
310 gallons wasted per month

120 drops per minute =
429 gallons wasted per month

Source: California Urban Water Conservation Council

Some water leaks, such as a dripping faucet, are obvious. Other water leaks can be virtually invisible, such as a leaky toilet flapper valve or a leaky irrigation pipe in your yard. While this brochure is not intended to address major plumbing problems, it is designed to give you an overview of how preventive maintenance and diligent repair are important aspects of water conservation. By following the advice in this brochure, you'll be able to conserve water while you help keep your pipes, plumbing fixtures and water-using appliances in top shape.

Water conservation shouldn't be something we think about only during a drought. As the competition for our most precious natural resource grows, let's make conserving water an everyday part of life in New Mexico.



photo courtesy of Kohler

Section One: Water Basics



THE TWO COMMON
METER TYPES
Straight-reading (left)
Circular-reading (right)

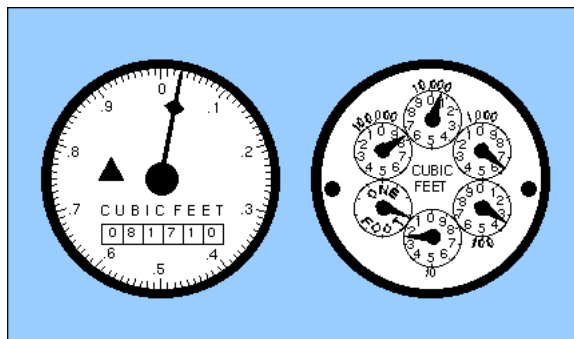
Water Meters and Leak Detection

A water meter keeps track of how much water passes through it. The readings from your water meter determine the amount that you are billed for water usage by your water utility each month. What you might not have realized is that a water meter can also be a most valuable tool in determining if you have any water leaks.

In suburban neighborhoods, most water meters are located under a metal lid by the front curb or sidewalk. In rural areas, the water meter is typically located where the water service connection enters the property. (If you can't locate your water meter or have questions, call your water utility.) There are two common types of water meters:

Straight-reading meters record either cubic feet or gallons of water much like a car odometer records miles. The dial with the single hand records tenths of a cubic foot.

Circular-reading meters also record cubic feet or gallons of water. But instead of a single line of numbers, a circular reading meter has a series of dials that record each digit: 100,000, 10,000, 1,000, 100, etc. To determine the current reading, start with the 100,000 dial and work your way down. If a dial hand is between two numbers, read the lower number.



Master Valves and Shutoff Valves

To use your water meter as a leak detector, just follow these easy steps:

1. Turn off all water-using appliances, including your automatic icemaker and evaporative cooler.
2. Record the reading on your water meter.
3. Wait 30 minutes.
4. Record the new reading on your water meter.

If the reading has changed, you have a leak. Use the information in this brochure to help you locate and fix the leak.

NOTE: The water meter is the property of your local water utility. If the water meter leaks, or if you suspect that the meter is not functioning properly, call the water utility.

Water Facts

*** 1 cubic foot of water = 7.48 gallons**

** Most water utilities bill in "units" of water. Some utilities consider one unit to be 100 cubic feet of water (equal to 748 gallons); other utilities define one unit as 1,000 gallons.*

The master water supply valve controls the water supply to your home. It's a good idea to know where your master water valve is located, so you can turn off the water supply in the event of a major leak or as needed when making a plumbing repair.

The two most common locations for the master supply valve are next to the water meter or where the water supply pipe enters your home. To shut off the water supply, slowly turn the handle clockwise. (Many water supply valves require a special two-pronged "key" to turn the handle. Water supply keys can be purchased at most plumbing, hardware and home improvement stores.)

Plumbing codes now also require new houses to have a main shutoff valve inside the house. The valve can be located under any plumbing fixture, but the most common location is next to the water heater.

To make sure that the master valve has indeed shut off the water, turn on a faucet. If water flows, the master valve hasn't completely shut off the water.

Most homes and businesses also have shutoff valves for the water lines that run to individual water fixtures. For example, the shutoff valve for a toilet is located below the toilet tank. The shutoff valves for a kitchen or bathroom faucet are located under the sink. (There is one shutoff valve for the hot water line and another valve for the cold water line.) The typical faucet or toilet shutoff valve has an oval handle. Turn the handle clockwise to turn off the water supply.

Section Two: Finding and Fixing Indoor Leaks

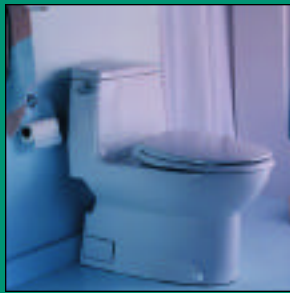


photo courtesy of Toto

Anatomy of a Typical Toilet

The most common type of toilet is called a “gravity-fed toilet” because it uses the weight and height of the water in the tank to generate the force needed to flush waste through the bowl. The mechanics of the basic gravity-fed toilet have not changed much in the past century, so a gravity-fed toilet is still relatively easy to adjust and repair.

6

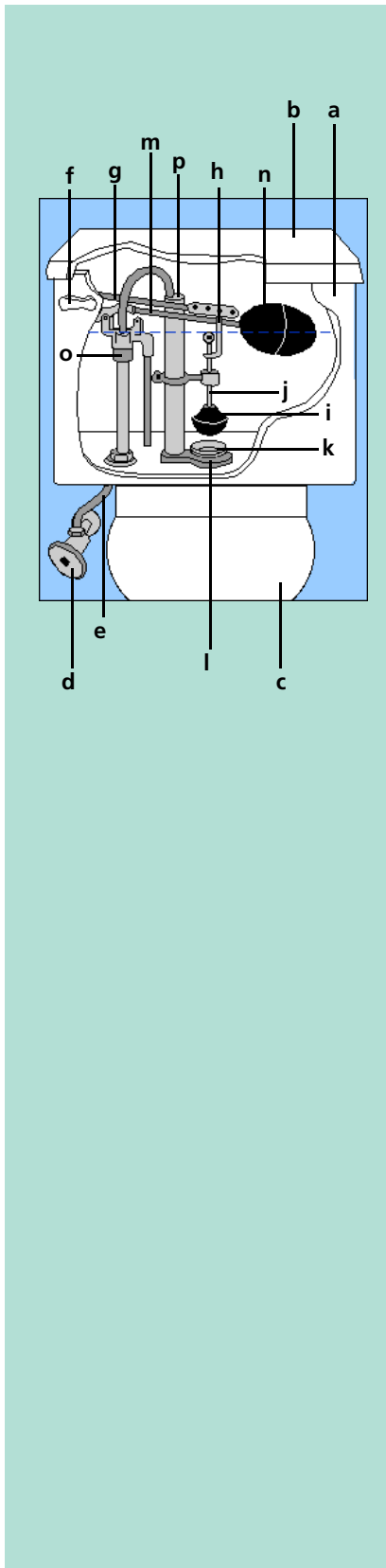
Toilets

How much water your toilet uses depends on two factors: its tank size and its working condition. Since 1992, federal law has mandated that all new toilets use no more than 1.6 gallons per flush. If your toilet is a 3.5 gallons-per-flush model from the 1980s or an even older model that uses five or more gallons per flush, consider replacing your old water guzzler with a sleek, new water-conserving 1.6 gallon unit. Some municipal water utilities (including the City of Albuquerque) offer a credit on your water bill when you replace an old toilet with a water-efficient one.

But even the new “ultra-low-flush” toilets can be water wasters. A leaky flapper valve or an improperly set water level in the tank can cause significant water leakage. And not every “running” toilet makes noise. Follow the instructions in this section to check your toilet for water leaks and repair the problem.

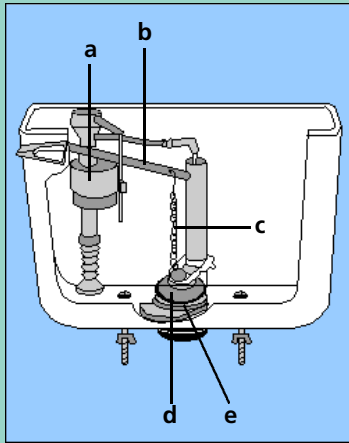


photo courtesy of Fluidmaster



Float Ball/Tank Ball Models

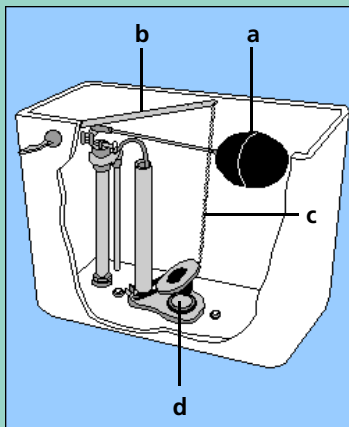
- a. **Tank**– The top portion that holds water waiting to be flushed. Also inside are the flush mechanisms and components.
- b. **Tank lid**– The cover that sits on the tank and conceals the flush mechanisms.
- c. **Bowl**– The lower half of the toilet that holds waste prior to flushing.
- d. **Water shutoff valve**– The valve located on the wall near the base of the toilet (typically with an oval or round handle) that controls the flow of water into the toilet tank.
- e. **Water supply line**– A hose-like line, typically made of flexible material, that connects the water shutoff valve to the bottom of the tank.
- f. **Flush handle**– The mechanism that is pushed to activate the flush.
- g. **Lift arm**– The metal or plastic rod connected to the flush handle.
- h. **Lift wire**– The connecting link between the lift arm and the tank ball.
- i. **Tank ball**– The rubber ball that sits in the flush valve (the hole in the bottom of the tank) to keep water in the tank until the flush.
- j. **Guide arm**– A fixed piece, connected to the overflow pipe, which ensures that the tank ball falls snugly on the flush valve.
- k. **Flush valve**– The opening through which water flows from the tank to the bowl.
- l. **Valve seat**– The rubber seal at the bottom of the tank into which the tank ball fits.
- m. **Float arm**– The metal or plastic rod connected to the ball cock at one end and the float ball at the other. The angle of the float arm is what tells the ball cock to shut off the water supply to the tank.
- n. **Float ball**– A hollow rubber ball that rises and falls with the water level in the tank.
- o. **Ball cock valve**– The tall mechanism on the left-hand side of the tank that controls the flow of water into the tank.
- p. **Overflow pipe**– The vertical pipe that drains excess water from the tank to prevent overflow.



Float Cup*/Flapper Models

- a. **Float cup**– A variation on the float ball, a float cup performs the same basic function, rising and falling with the water level in the tank. When the float cup rises high enough along the ball cock tube, it triggers the ball cock to stop the flow of water into the tank.
- b. **Lift arm**– The metal or plastic rod connected to the flush handle.
- c. **Lift chain**– The connecting link between the lift arm and the flapper.
- d. **Flapper**– The flush valve seat that controls the volume of water passing from the tank to the bowl during a flush.
- e. **Flush valve**– The opening through which water flows from the tank to the bowl.

* sometimes called a vertical ballcock



Float Ball/Flapper Models

- a. **Float ball**– A hollow rubber ball that rises and falls with the water level in the tank.
- b. **Lift arm**– The metal or plastic rod connected to the flush handle.
- c. **Lift chain**– The connecting link between the lift arm and the flapper.
- d. **Flapper**– The flush valve seat that controls the volume of water passing from the tank to the bowl during a flush.

Another type of toilet is the pressure-assisted toilet, which uses air pressure within a cylindrical tank inside the toilet tank to propel the water during a flush. Tuning up a pressure-assisted toilet is best left to a professional plumber.

Is Your Toilet Leaking? Give It the Dye Test

Even though you might think your toilet isn't leaking, there's one sure-fire way to find out. Lift the lid off the toilet tank and put 10-15 drops of dark-colored food dye into the tank. After 15 minutes, check the toilet bowl for any signs of dye color. If there's color in your bowl, your toilet is leaking. Read on.

Common Toilet Problems

Leaks and noises are the most common problems with tank toilets, and the two types of problems are often interrelated. (However, some leaky toilets are silent.) The good news: many common toilet leaks can be fixed by making minor adjustments. Let's go through some of the most common reasons toilets leak and the steps you'll need to follow to fix them.

Illustration 1

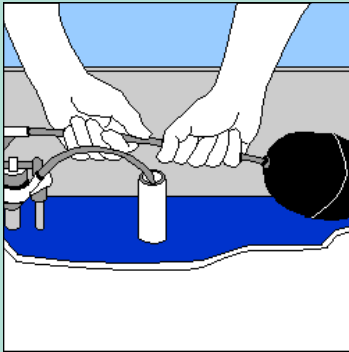


Illustration 2

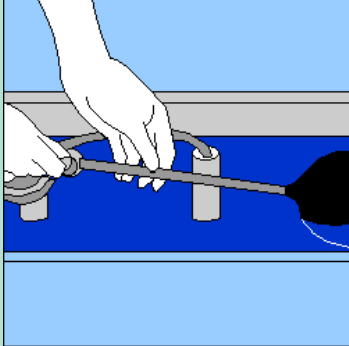
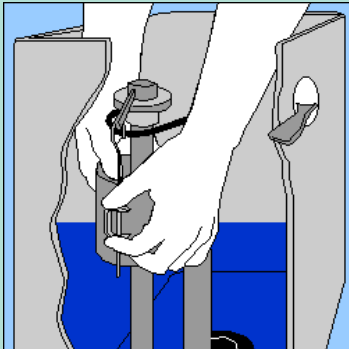


Illustration 3



Toilet "runs" all the time, or periodically between flushings. (You hear the sound of running water.)

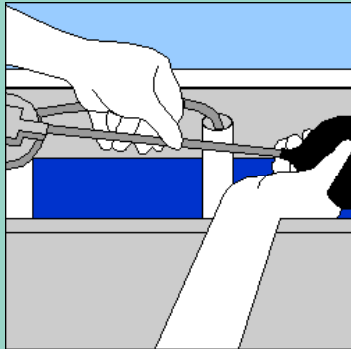
A running toilet can be caused by an improperly adjusted float ball that results in a water level in the tank that's so high that water is escaping into the top of the overflow pipe. A running toilet can also be caused by a cracked float ball, an improperly seated flapper or tank ball, a kinked lift chain or a bent lift wire.

If the water level in the tank is too high:

Adjust the float arm.

- In older toilets with a metal float arm, you'll need to grab the float arm with both hands and gently bend the side with the float ball downward. (illustration 1)
- If your toilet has a plastic float arm, there's probably an adjusting knob located where the arm meets the ball cock. Loosen the knob and move the float arm and float ball downward. (illustration 2)
- If your toilet has a float cup instead of a float ball, pinch the spring clip on the side of the float cup and slide the float cup a bit lower. (illustration 3)
- Some toilets have a "floatless ball cock" that controls the water level with a pressure-sensing device. To adjust the water level on a floatless ball cock, turn the adjustment screw on top of the ball cock. Turn the screw clockwise to raise the water level and counterclockwise to lower it.

(continued next page)



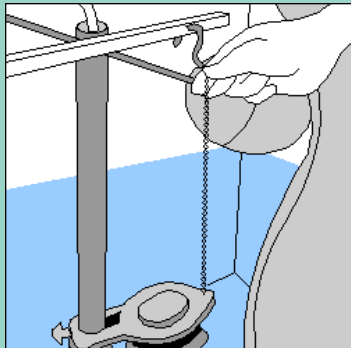
Flush the toilet and check the new water level. It should be about 1/2 inch below the top of the overflow tube (or at the line etched on the inside back of the tank). If a simple water-level adjustment doesn't fix the problem, you might need to:

Replace the float ball.

If the float ball is cracked, it will fill up with water and never rise high enough to tell the ball cock valve to shut off the water. The float ball will be fully or partially submerged and the water level in the tank will be so high that water flows into the overflow pipe.

- Remove the float ball by unscrewing it counterclockwise.
- Coat the threads of the float arm with petroleum jelly.
- Screw a new float ball onto the float arm.

If jigging the handle stops the toilet from running:

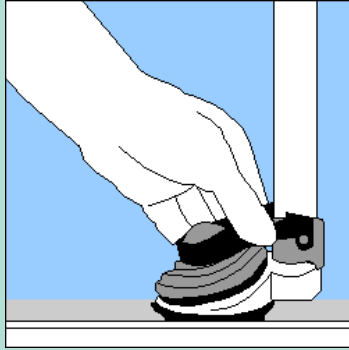


Check the guide wire or lift chain.

- For flappers with lift chains: Make sure the chain isn't kinked or hung up on the float arm or float ball. Try adjusting the chain by hooking it into a different hole on the lift arm (which is attached to the flush handle).
- For tank balls with guide wires: Check to see that the tank ball is fitting properly on the valve seat. To readjust a tank ball mechanism, loosen the thumbscrew that fastens the guide arm to the overflow pipe. Reposition the arm and the lift wire so that the tank ball is right above the flush valve.

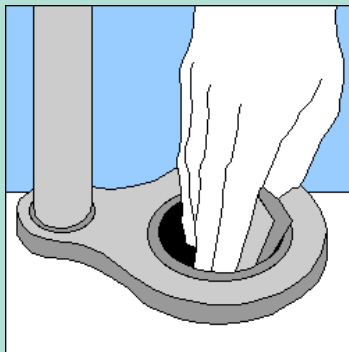
If the water level looks fine but the dye test shows that the toilet leaks:

The two most common culprits are the valve seat, which may need to be cleaned, and the flapper (or tank ball), which may need to be adjusted, cleaned or replaced. (See next page.)



Adjust the flapper (tank ball).

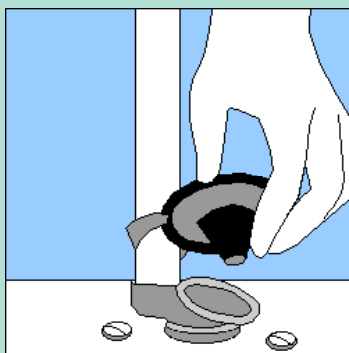
- Check to see if the flapper (tank ball) is fitting properly on the valve seat.
- Turn off the water shutoff valve located just underneath the toilet tank (by turning the valve clockwise until it stops). Then flush the toilet to drain the tank. See if the flapper/tank ball falls straight onto the flush valve opening.
- Adjust the flapper/tank ball by loosening the thumbscrew that fastens the guide arm to the overflow pipe.
- Reposition the arm and the lift wire so that the tank ball is right above the flush valve. (Or adjust the flapper so that it will fall directly onto the valve seat.)



Clean the flapper (tank ball) and valve seat.

If the flapper (or tank ball) is sitting correctly in the valve seat but water is still leaking into the bowl, the problem may be a build-up of mineral deposits on the flapper and/or valve seat.

- Turn off the water shutoff valve located just underneath the toilet tank (by turning the valve clockwise until it stops). Then flush the toilet to drain the tank.
- Clean the valve seat and the flapper with fine steel wool or a plastic cleansing pad to make sure they are both smooth and free of mineral deposits.
- Turn on the water shutoff valve and conduct the dye test again to check for leaks.



Replace the flapper (tank ball).

If you've checked to make sure the flapper (tank ball) is correctly positioned in the valve seat and both parts are clean but you still have a leak, your flapper is probably worn. A worn flapper won't seal properly. To replace a flapper:

- Turn the water shutoff valve and flush the toilet to drain the tank.
- Remove your old flapper and take it with you to the hardware or plumbing store so you can buy a replacement.
- Before installing the new flapper, clean the valve seat with fine steel wool or a plastic cleansing pad to make sure it's smooth.
- Install the new flapper. Then run the dye test again to make sure you have fixed the leak.

NOTE: Make sure your replacement flapper matches the model and water-use requirements of your existing flapper. If your toilet is a 1.6 gallons-per-flush model, make sure you buy the correct 1.6 gallons-per-flush flapper. Not all generic flappers work equally well. Some toilets rely on a specific flapper to create the low-flow flush.

If the toilet STILL leaks:

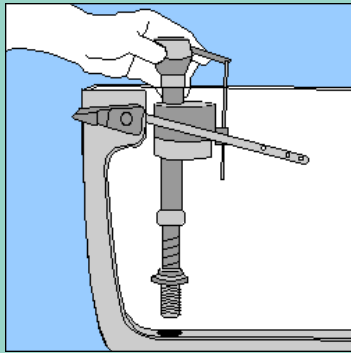
If none of the above procedures has fixed the leak, or the toilet is making a high whine or whistle when the tank is filling up, consider replacing the ball cock, the mechanism that controls the flow of water into the toilet tank. Replacement ball cocks are sold at plumbing, hardware and home improvement stores.

Replace the ball cock.

Although it is possible to replace an older ball cock with a new one, consider replacing it with a new float cup valve, which many plumbers prefer because it is less prone to leaking.

- Turn off the water shutoff valve and flush the toilet to drain the tank.
- Disconnect the water supply tube from the bottom of the tank.
- Remove the float arm from the ball cock.
- Remove the refill tube from the top of the ball cock.
- Loosen the nut under the tank that holds the ball cock into place. If the ball cock turns when you try to loosen the nut, hold the ball cock with one hand while loosening the nut under the tank with your other hand. Once the nut is removed, lift the ball cock out of the tank.
- Install a new float cup valve into the tank and tighten the nut on the underside of the tank.
- Attach the refill tube to the float cup and to the overflow tube.
- Reconnect the water supply tube and turn on the water supply.
- Adjust the float cup until the water level is about 1/2 inch below the top of the overflow tube. To adjust the water level, simply pinch the spring clip on the side of the cup and move the cup higher (to raise the water level) or lower (to lower the water level.)

If none of the above procedures works, call a professional plumber!



The National Energy Policy Act of 1992 set these standards for new fixtures manufactured in the U.S.:

- toilets use no more than 1.6 gallons per flush
- showerheads use no more than 2.5 gallons per minute
- kitchen and bathroom faucets not exceed 2.5 gallons per minute.

Faucets

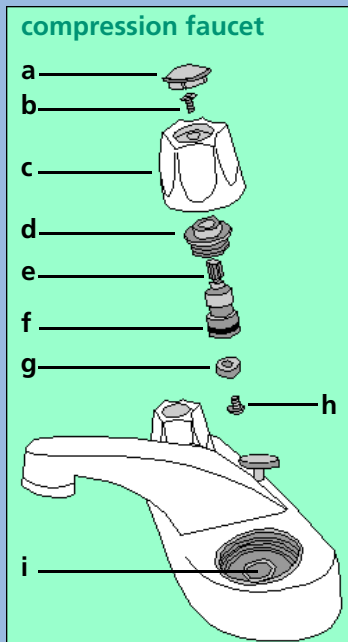
A leaky faucet is a common household water waster. A steady drip at the rate of one drop per second wastes 192 gallons of water in a month!

The first step in fixing a leaky faucet is to identify the faucet type. Although there are hundreds of different styles, sizes and shapes, faucets can be divided into two basic types:

Compression faucets, sometimes called stem faucets, always have two handles, one for hot water and one for cold water.* When the handle is turned on, the stem rotates. The threads cause the stem to rise, moving a rubber washer away from the faucet seat and allowing water to flow. When turning the faucet off, you can sometimes feel the rubber washer being squeezed against the faucet seat to stop the flow of water.

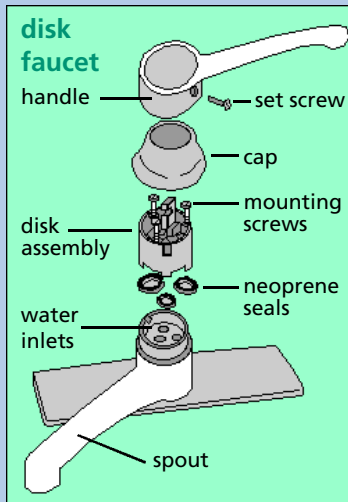
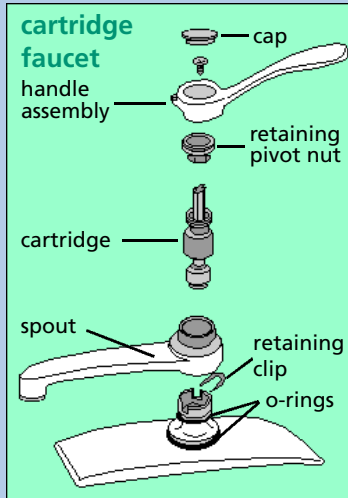
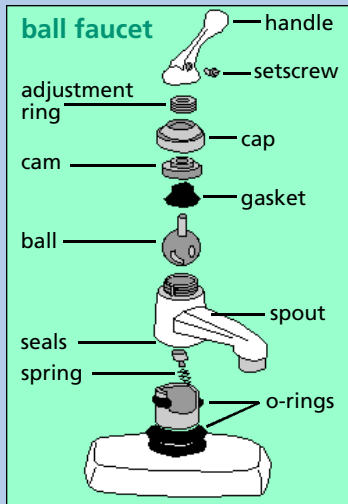
**NOTE: The exceptions to this "two handles" rule are cold-water-only single faucets, such as hose bibbs, which are also compression faucets.*

photo courtesy of Delta Faucets



- a. decorative cap
- b. handle screw
- c. handle
- d. retaining (packing) nut
- e. stem
- f. packing washer or o-ring
- g. seat washer
- h. seat screw
- i. valve seat





Washerless faucets typically have just one handle that controls both the hot and the cold water. Washerless faucets are known for providing years of trouble-free service because their design minimizes friction and wear. There are three primary types of washerless faucets:

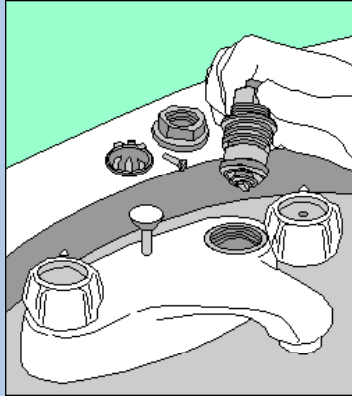
- A **ball faucet** has a single handle over a dome-shaped cap.
- A **cartridge faucet** has a narrow plastic or metal cartridge inside the faucet body. Most cartridge faucets are single-handle models, but some two-handled faucets use cartridge designs.
- A **disk faucet** has a single handle and a wide cylinder inside the faucet body.

Helpful Tips

- Turn off the water before you start any faucet repair. The shutoff valves for indoor faucets are underneath the sink. Turn the left knob clockwise to shut off the hot water; turn the right knob clockwise to shut off the cold water.
- Before disassembling a faucet, cover the sink with a towel to protect it from dropped tools and to prevent small parts from going down the drain.
- When dismantling parts, line them up in the order and orientation in which they were removed to make it easier to properly reassemble the pieces.
- When using metal tools on a polished surface, protect the polished surface with a rag or several layers of masking tape.
- Take the old parts with you when you go to a plumbing or hardware store to buy replacement parts. This will help ensure that you get the right parts for the job.
- Most faucet repair kits come with good instructions. Follow them!

Conservation Fact

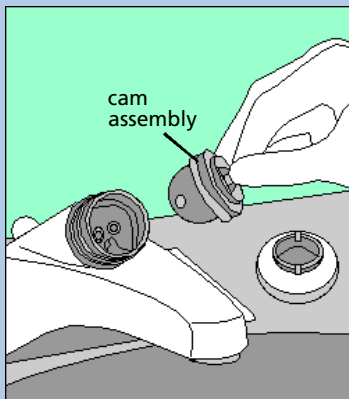
The flow rate of a faucet is measured in gallons per minute (gpm). Older kitchen and bathroom faucets can have a maximum flow rate of 3 to 7 gpm. Since 1992, the maximum allowable flow rate is 2.5 gpm. But no matter how thrifty a faucet's flow rate, leaving the tap running is a most wasteful practice.



Fixing a compression faucet

To fix a leaking compression faucet, first determine whether it's a hot water leak or a cold water leak. If you can't tell from the temperature of the dripping water, turn off the hot water supply valve under the sink. If the drip stops, it's the hot water stem that's leaking. If the drip continues, the culprit is the cold water faucet.

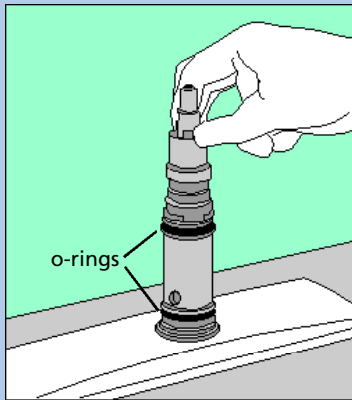
- Remove the handle screw. (It may be hidden under a decorative cap or behind the handle.) Remove the handle.
- Unscrew the retaining (packing) nut.
- Remove the stem by either jiggling it from the valve seat or unscrewing it counterclockwise with a wrench.
- To replace the washer on a standard stem, remove the seat screw at the bottom of the stem and pry out the old washer with a screwdriver. Install a new washer.
- For some compression faucets, you'll also need to replace the packing washer or packing string, which prevents water from leaking at the faucet handle.
- Check the valve seat (the metal that the washer seals on) for damage by running your finger along the rim of the seat. If it's pitted and not completely smooth, remove the valve seat using a seat wrench. Install a new valve seat.
- Reassemble the parts.



Fixing a ball faucet

- With an allen wrench, loosen the setscrew at the base of the handle. Remove the handle.
- Underneath the handle you'll find a protective cap with an adjusting ring. Sometimes a dripping ball faucet can be fixed by tightening this ring. Turn it clockwise gently.
- If tightening the ring doesn't stop the leak, close both shutoff valves beneath the sink.
- Unscrew and lift off the cap, plastic cam, cam gasket and rotating ball.
- Rubber faucet seats are held against the bottom of the ball by small springs. Using the point of a screwdriver or a pair of needle-nose pliers, gently remove the two seats and springs. Remove any loose debris.

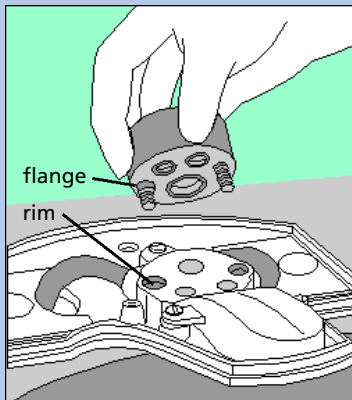
(continued next page)



- Install new seats and springs from a repair kit. (Follow the instructions provided in the repair kit.) Also, lift the spout and replace the two O-rings. (Apply a light coating of petroleum jelly or valve grease to the new O-rings before installing them.)
- Reassemble the faucet and tighten the adjusting ring enough to prevent leaks without making the handle difficult to operate.

Fixing a cartridge faucet

- Shut off both water supply valves underneath the sink.
- Remove the decorative cap (if any) and remove the handle screw. Remove the handle.
- Unscrew the retainer nut.
- Some models have a U-shaped clip that holds in the cartridge. Use needle-nose pliers or the tip of a screwdriver to remove the clip.
- The cartridge fits tightly in the faucet body. Remove the cartridge by pulling up on it firmly with a pair of pliers.
- Replace damaged O-rings and lubricate the new ones with petroleum jelly or valve grease. If the cartridge is worn or damaged, replace it with an identical part. (Cartridge repair kits typically contain a new cartridge, new O-rings and grease.)
- Install the new cartridge, making sure that the notch in the stem faces the sink.
- Reattach the U-clip, retainer nut, handle, handle screw and decorative cap.



Fixing a disk faucet

- Shut off both water supply valves underneath the sink.
- Remove the setscrew from the handle. Lift off the handle and remove the body cover (escutcheon cap).
- Remove the disk assembly as a unit by unscrewing the mounting screws. Pull the disk out.
- Turn the disk over and remove any dirt lodged between the ceramic disks.
- Remove the rubber seals from the cylinder openings. Clean the cylinder openings and flush out any debris.
- Install new rubber seals and reassemble the faucet.
- If the faucet still leaks, replace the entire disk assembly with a new one.

Faucet Aerators



There are two common sizes of aerators:

- If a nickel fits snugly into the threaded end of an aerator, it's a standard-sized aerator (15/16-inch male threads or 55/64-inch female threads).
- If a nickel doesn't fit but a dime does, it's a small aerator (13/16-inch male threads or 3/4-inch female threads).

Most indoor faucets have an aerator at the tip of the faucet spout. An aerator is a screw-on attachment with a small wire screen that mixes tiny air bubbles into the water to create a smooth flow. A faucet aerator is an inexpensive and efficient water conservation device because it reduces water flow without an apparent reduction in water pressure or volume. Older faucets without aerators typically deliver water at five gallons per minute (gpm). Newer faucets (with aerators) are required to deliver no more than 2.5 gpm, and some water-wise faucets deliver just 1.5 gpm.

Clean and Replace Aerators

If the water flow from a faucet spout is partially blocked or the water pressure seems low, take the aerator apart and clean it or replace it.

- Protect the chrome finish on the aerator with masking tape or a cloth, and unscrew the aerator with pliers or a wrench.
- Clean the screen by soaking it in vinegar and scrubbing it with an old toothbrush.
- Replace the washer if it is worn out. If the aerator is visibly damaged, or if its flow rate is more than 2.5 gpm, replace it.
- Reassemble the aerator and thread it back onto the faucet spout by hand. Gently tighten it into place with pliers or a wrench.

"Male" and "Female" Aerators

When replacing a faucet aerator, it's important to use the correct type for your faucet. If the threads are on the inside, it has "female" threads. If the threads are on the outside, it has "male" threads.

Showerheads



photo courtesy of Kohler

Conservation Tip

The maximum flow rate of pre-1980 showerheads in the United States was 5 to 8 gallons per minute (gpm). In the 1980s, 3 gpm showerheads became the industry standard. Today, 2.5 gpm is the standard. If you've got an older showerhead, consider replacing it with a new water-efficient model.

Shower and tub faucets share the same basic designs as sink faucets. Therefore, the repair techniques are the same. In many cases it is necessary to take off the handle and disassemble the faucet to identify the faucet type. Here are some general identification guidelines:

- **Three-handle faucets** (hot, cold and a separate diverter valve for the showerhead) have either compression or cartridge designs.
- **Two-handle faucets** (hot and cold, with a showerhead/gate diverter on the tub spout) have either compression or cartridge designs.
- **One-handle faucets** have either cartridge, ball-type or disc designs.

For information on fixing a leaky showerhead, refer to the information and illustrations in the Faucets section.

NOTE: Because some shower valves are set deep into the wall, special tools may be necessary. If you don't have access to the tools required for the job, call a plumber.

Dishwashers



photo courtesy of Whirlpool

Conservation Tip

Maximize water efficiency by washing only full loads, or use the correct setting for the size of the load and/or the type of wash required. If you're planning to use the dishwasher immediately after a meal, consider not rinsing the dishes—just scrape them and load them into the dishwasher.

In recent years, dishwasher manufacturers have made impressive strides in making their machines more water efficient. Some new resource-efficient models use less than 5 gallons per load on the normal wash setting, while older dishwashers can use up to 15 gallons per load. By comparison, a study conducted by Ohio State University showed that 16 gallons of water are used to hand-wash eight place settings and serving pieces (Buzzelli, 1991, p.57).

Although dishwasher leaks are relatively uncommon, the list below describes a few of the possible leaks and how to fix them. For more detailed information, consult the owner's manual or contact a professional plumber.

Water leaks from the door.

- The most likely culprit is the rubber gasket around the door. If the gasket has cracked or become hard and brittle with age, replace it with a new gasket.

Water leaks from the bottom during the wash cycle.

- Start by checking the gasket. If it is cracked along the bottom, replace it.
- If it's not the gasket, check the hose connections. Remove the access panel on the front of the dishwasher (at the bottom). Check the condition of the water supply hoses, and make sure the couplings are tight and free of leaks. Replace any worn or cracked hoses.

Dishwasher won't stop filling.

- Turn off the water supply valve and leave the dishwasher door shut. Let the machine complete its wash cycle.
- Open the dishwasher door and check the float switch. (It's located on the bottom of the water pan, typically in one of the corners.) The float should move up and down easily. Jiggle it to see if it will function. If the float switch doesn't appear to be working, replace it or call a repair service.

Washing Machines



photo courtesy of Whirlpool

Helpful Hint About Appliances

Because of the wide variety of appliance brands and the many differences between individual models, always consult the owner's manual before attempting any appliance repair. In addition, the Internet is a rich resource for troubleshooting guides and manufacturers' specifications. A good starting place for website information is www.doityourself.com.

In most homes, clothes washing and toilet flushing consume the most water. If you use your clothes washing machine more than twice a week, then washing clothes is probably your largest indoor water-use-activity — unless you still have older (pre-1992) inefficient toilets.

Fortunately, new washing machines are more water- and energy-efficient than ever. While most older washing machines use 40 to 45 gallons to wash an extra-large load, many newer, water-thrifty models use as little as 15 gallons for a full load (depending on the capacity and model).

To make sure your washing machine is water-wise, wash only full loads and check your machine for leaks. Unless you have heavily soiled items, use cold or warm water rather than hot water, and reduce the number of rinses if your machine has these adjustment features. When it's time to buy a new washing machine, make sure you buy a water-efficient model. The most efficient models may cost more initially, but most families can save enough water and energy over the life of the machine to pay for the entire cost of the washer!

To fix a leaky washing machine, follow the steps below. For more detailed information, consult the owner's manual or contact a professional plumber.

Water leaks when washer is filling.

- Locate the source of the leak. Start by checking the water inlet valves. There will be one valve for hot water and one for cold water. (Often they resemble the hose bibbs that are found outside the house.)
- If water is leaking from the inlet valve or hose bibb, tighten the packing nut and hose connections with a wrench.

- Check the inlet hoses for cracks. If necessary, replace the hoses.
- Check the nozzle hose (inside the machine, connected to the inlet valve). Replace it if it is cracked.

Machine leaks when full.

- Check the pump hoses for loose connections or cracks. (To access the pump hoses, unplug the machine, turn off water supply valves, remove supply hoses, and remove the rear service panel.)
- If the connections are tight and the hoses are intact, the pump may be faulty and need replacement. Locate the source of the leak. Start by checking the water inlet valves. There will be one valve for hot water and one for cold water. (Often they resemble the hose bibbs that are found outside the house.)



photo courtesy of A.O. Smith Water Products

Energy Conservation Tip

Set the water heater thermostat to 120° F. You'll save energy and prevent accidental scalding from too-hot water.

Water Heaters

Water heaters heat and store water — usually from 30 to 50 gallons — for on-demand use. To prevent and fix potentially serious water heater leaks, follow the basic maintenance tips below.

Conduct a Visual Inspection

Most water heaters provide trouble-free performance for many years, but it's still a good idea to inspect your water heater periodically for possible leaks or other problems. Start by looking for leaks at the base of the water heater. Examine the piping, and tighten any loose connections. If water is leaking from the drain valve or the temperature-pressure relief valve, read the sections that follow. If water is leaking through the tank itself, replace the water heater as soon as possible.

(continued on next page)



Drain Valve



Temperature Relief Valve

photos courtesy of A.O. Smith
Water Products

Fixing a Leaky Drain Valve

Perhaps the most common water heater leaks occur at the drain valve. Sometimes tightening the valve (by turning the knob clockwise) will stop the leak. If that doesn't work, consider one of these options:

- If the leaking drain valve is brass, replace the packing washer or stem washer. (See the Faucets section for a detailed description.)
- Install a brass hose cap (with a rubber hose washer inside) onto the threads of the drain pipe. Tighten the hose cap with pliers to get a good, water-tight seal.
- If the drain valve is plastic, consider replacing it with a 3/4-inch ball valve or hose bibb, which is less likely to leak.

Check the Temperature-Pressure Relief Valve

By regulation, all domestic water heaters are equipped with a temperature-pressure relief valve (TPRV) that automatically opens when the temperature and/or pressure in the water heater gets dangerously high. If the valve is constantly dribbling water, the thermostat may be set too high. Adjust the dial to a lower setting.

If water still dribbles from the TPRV, the valve may be stuck open slightly. Place a bucket below the discharge pipe, then lift the lever on top of the valve a few times to let some water run out. If the valve still leaks, replace it. (If you're not comfortable with major do-it-yourself plumbing projects, call a professional plumber.)

NOTE: Some TPRV valves can leak by design because of thermal expansion. (Heated water expands to fill more space than cold water.) Check the owner's manual for your water heater for more information.

Water Filters & Softeners



photo courtesy of Kineticco

Some homeowners choose to install water filters to purify their drinking water, and some homes have water softeners to remove “hardness” (i.e., calcium and magnesium, the minerals that lead to soap-curd deposits in the bathtub and sinks, spots on dishes, and scaly deposits on faucets, showerheads, and inside the water heater and pipes).

Water requirements for water softener regeneration vary from 15 to 120 gallons of water softened. Automatic water softeners use the most water, because they have a timer that automatically initiates the regeneration cycle whether or not the water is used. Demand-control softeners use the least water because they monitor water flow or changes in hardness to adjust regeneration to the actual demand for water. (When replacing an existing water softener, choose a demand-control softener if possible.)

Even under the best circumstances, water filters and water softeners can be notorious water users. To prevent leaks in water filters and softeners, regularly inspect supply tubes, pipes and connections. Tighten any loose fittings and replace any worn or broken parts.



**WATER USE AND
CONSERVATION
BUREAU**

New Mexico Office of
the State Engineer
P.O. Box 25102
Santa Fe, NM
87504-5102
1-800-WATER-NM
www.ose.state.nm.us

**Want More Information About Water
Conservation?**

Contact the following municipalities,
government departments, and organizations
to receive more information about how you
can conserve water:

New Mexico Office of the State Engineer
Water Use and Conservation Bureau
1-800-WATER-NM (1-800-928-3766)
www.ose.state.nm.us

City of Albuquerque
Water Conservation Office
(505) 768-3655
www.cabq.gov

City of Santa Fe
Sangre de Cristo Water Division
(505) 954-7199
www.ci.santa-fe.nm.us

WaterWiser
National Water Conservation Clearinghouse
www.waterwiser.org

Sources:

The Complete Guide to Home Plumbing, Black & Decker,
Creative Publishing International, Minnetonka,
Minnesota, 1998.

Do It! Fix Your Plumbing, Edited by Mary Yee, Chronicle
Books, San Francisco, California, 1994.

Ortho's Home Repair Problem Solver, Ortho Books, San
Ramon, California, 1995.

Plumbing, Time-Life Books, New York, New York, 1989.

Practical Plumbing Handbook, California Urban Water
Conservation Council, May 2001.